

**COMP2310/COMP6310**

**Systems, Networks, & Concurrency**

Convener: Prof John Taylor

# Overview of the Internet

**Acknowledgement of material:** With changes suited to ANU needs, the slides are obtained from **Carnegie Mellon University**: <https://www.cs.cmu.edu/~213/>

# Basic Internet Components

## ■ Internet backbone:

- collection of routers (nationwide or worldwide) connected by high-speed point-to-point networks

## ■ Internet Exchange Points (IXP):

- router that connects multiple backbones (often referred to as peers)
- Also called Network Access Points (NAP)

## ■ Regional networks:

- smaller backbones that cover smaller geographical areas (e.g., cities or states)

## ■ Point of presence (POP):

- machine that is connected to the Internet

## ■ Internet Service Providers (ISPs):

- provide direct access to POPs

# Internet Connection Hierarchy

*Private "peering" agreements between two backbone companies often bypass IXP*

*Colocation sites*

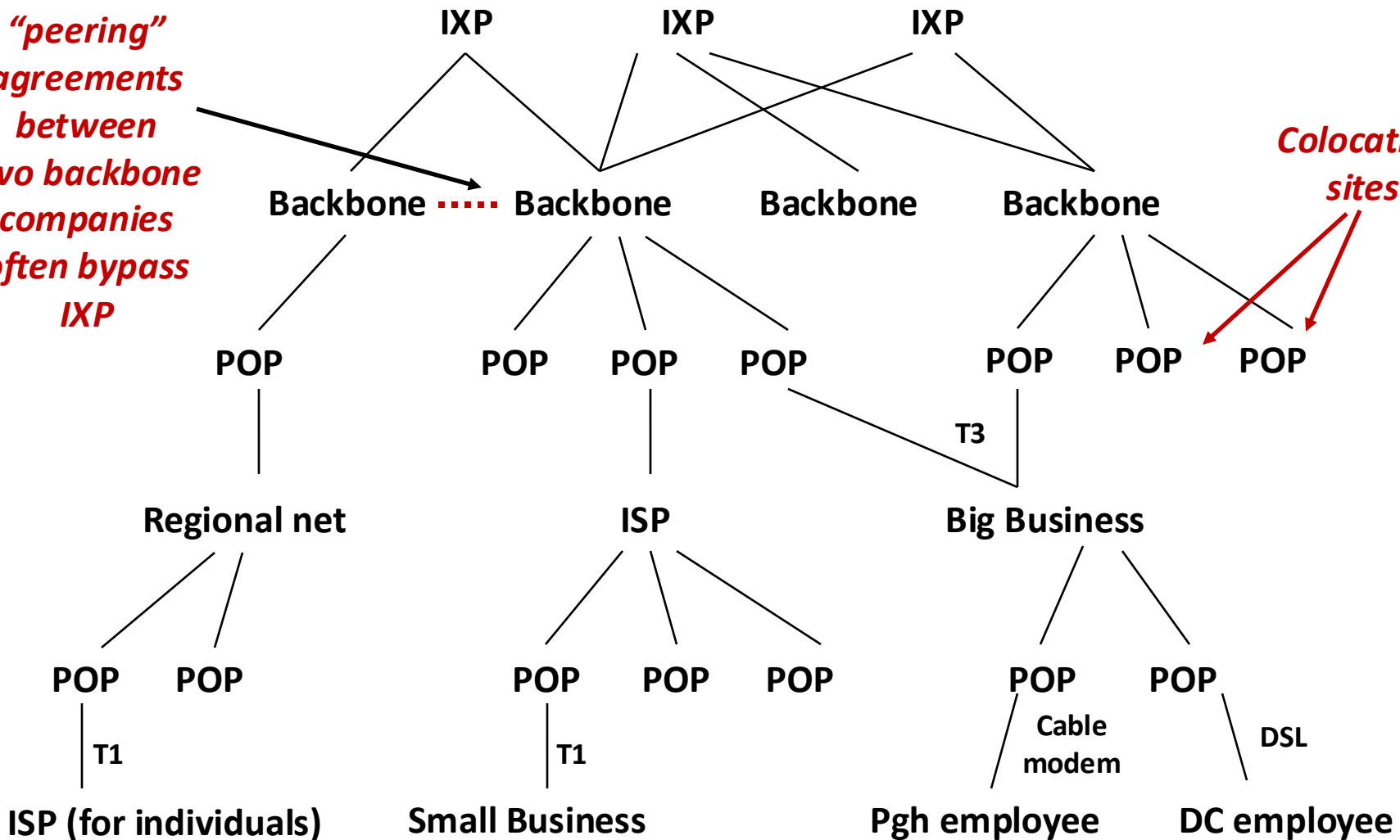

# IP Address Structure

- IP (V4) Address space divided into classes:

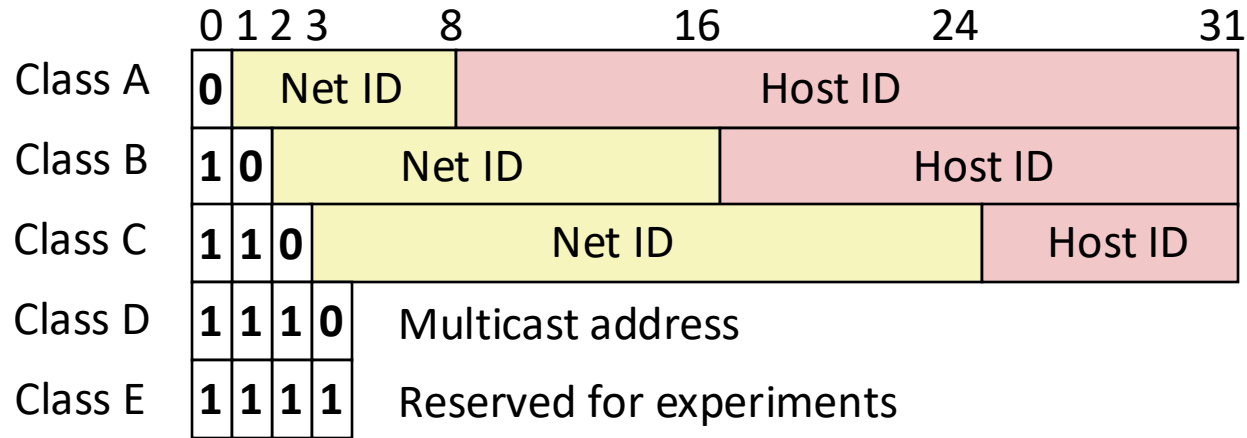

- Network ID Written in form  $w.x.y.z/n$

- $n$  = number of bits in host address
- E.g., CMU written as 128.2.0.0/16
  - Class B address

- Unrouted (private) IP addresses:

10.0.0.0/8   172.16.0.0/12   192.168.0.0/16

# Evolution of Internet

## ■ Original Idea

- Every node on Internet would have unique IP address
  - Everyone would be able to talk directly to everyone
- No secrecy or authentication
  - Messages visible to routers and hosts on same LAN
  - Possible to forge source field in packet header

## ■ Shortcomings

- There aren't enough IP addresses available
- Don't want everyone to have access or knowledge of all other hosts
- Security issues mandate secrecy & authentication

# Evolution of Internet: Naming

## ■ Dynamic address assignment

- Most hosts don't need to have known address
  - Only those functioning as servers
- DHCP (Dynamic Host Configuration Protocol)
  - Local ISP assigns address for temporary use

## ■ Example:

- Laptop at ANU (wired connection)
  - IP address 128.2.213.29 (**xyz . cs . anu . edu**)
  - Assigned statically
- Laptop at home
  - IP address 192.168.1.5
  - Only valid within home network

# Evolution of Internet: Firewalls

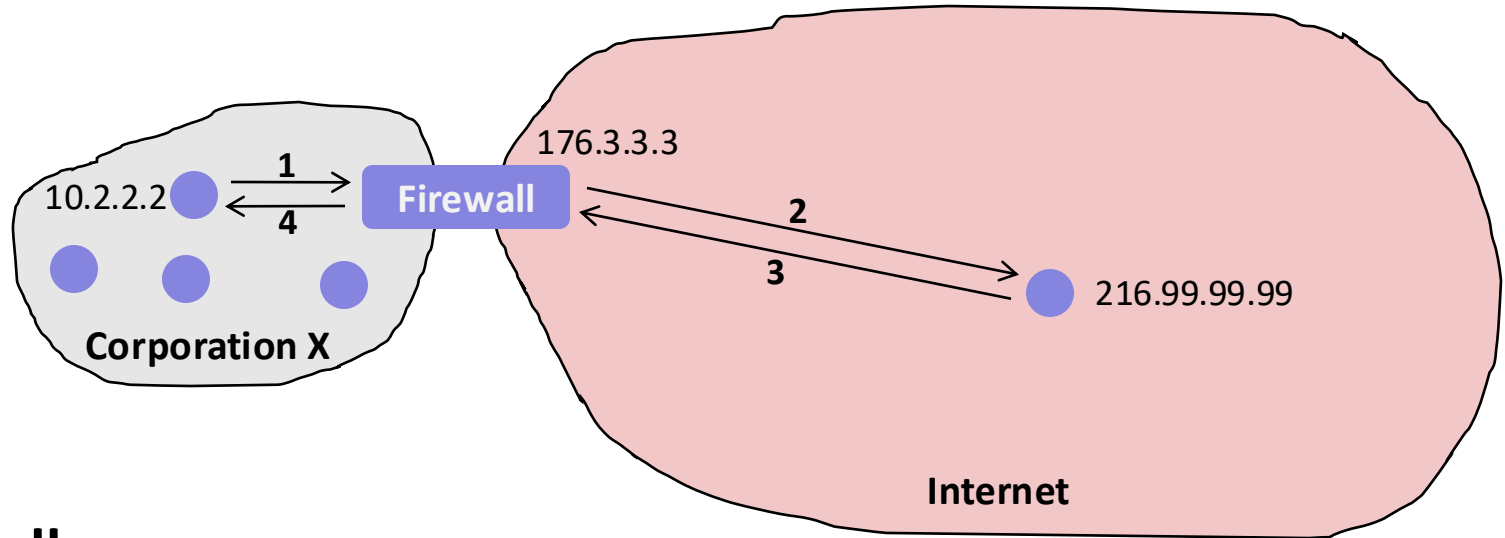

## ■ Firewalls

- Hides organizations nodes from rest of Internet
- Use local IP addresses within organization
- For external service, provides proxy service
  1. Client request: src=10.2.2.2, dest=216.99.99.99
  2. Firewall forwards: src=176.3.3.3, dest=216.99.99.99
  3. Server responds: src=216.99.99.99, dest=176.3.3.3
  4. Firewall forwards response: src=216.99.99.99, dest=10.2.2.2



# Network Programming: Part I

**Acknowledgement of material:** With changes suited to ANU needs, the slides are obtained from **Carnegie Mellon University**: <https://www.cs.cmu.edu/~213/>

# A Client-Server Transaction

- Most network applications are based on the client-server model:
  - A **server** process and one or more **client** processes
  - Server manages some **resource**
  - Server provides **service** by manipulating resource for clients
  - Server activated by request from client (vending machine analogy)

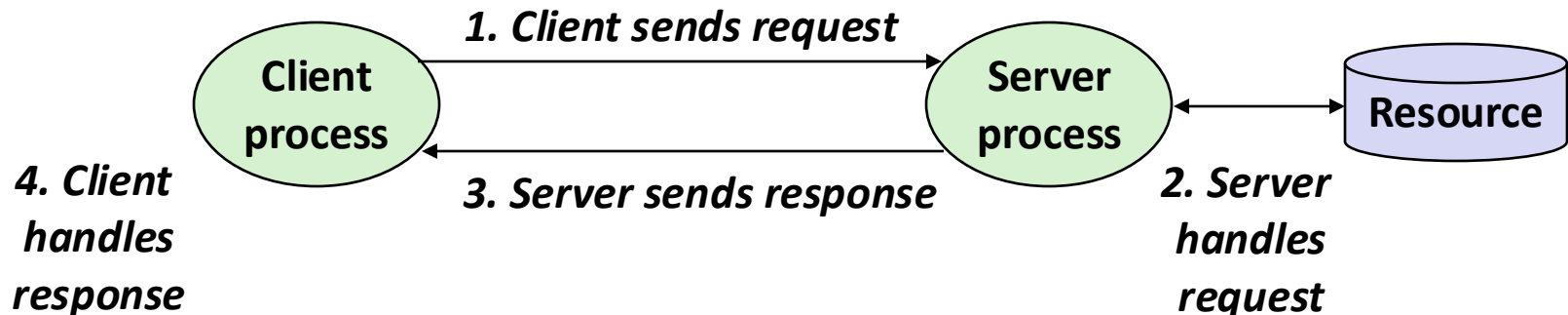

*Note: clients and servers are processes running on hosts (can be the same or different hosts)*

# Hardware Organization of a Network Host

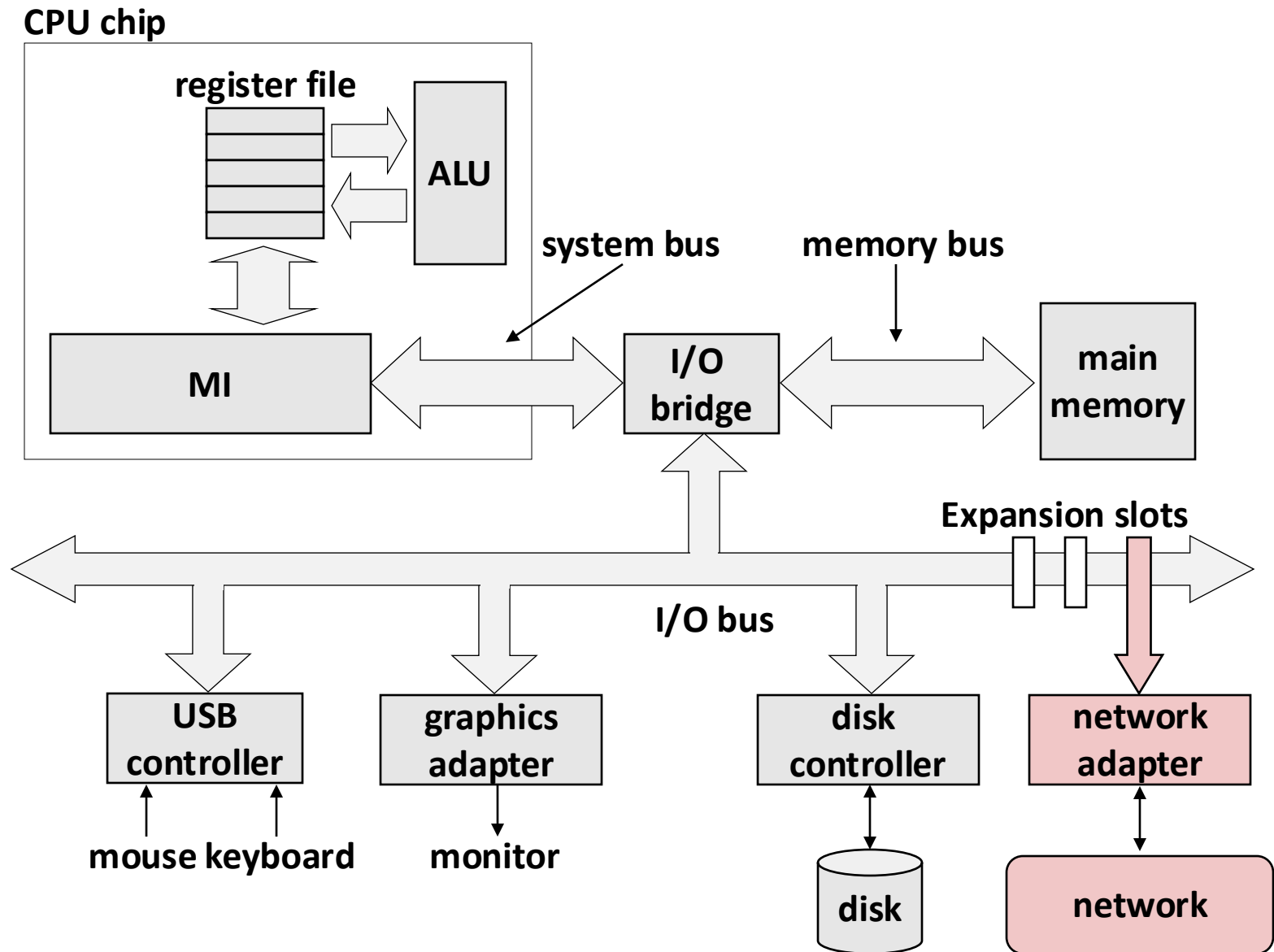

# Example Memory Hierarchy

↑  
Smaller,  
faster,  
and  
costlier  
(per byte)  
storage  
devices

↓  
Larger,  
slower,  
and  
cheaper  
(per byte)  
storage  
devices

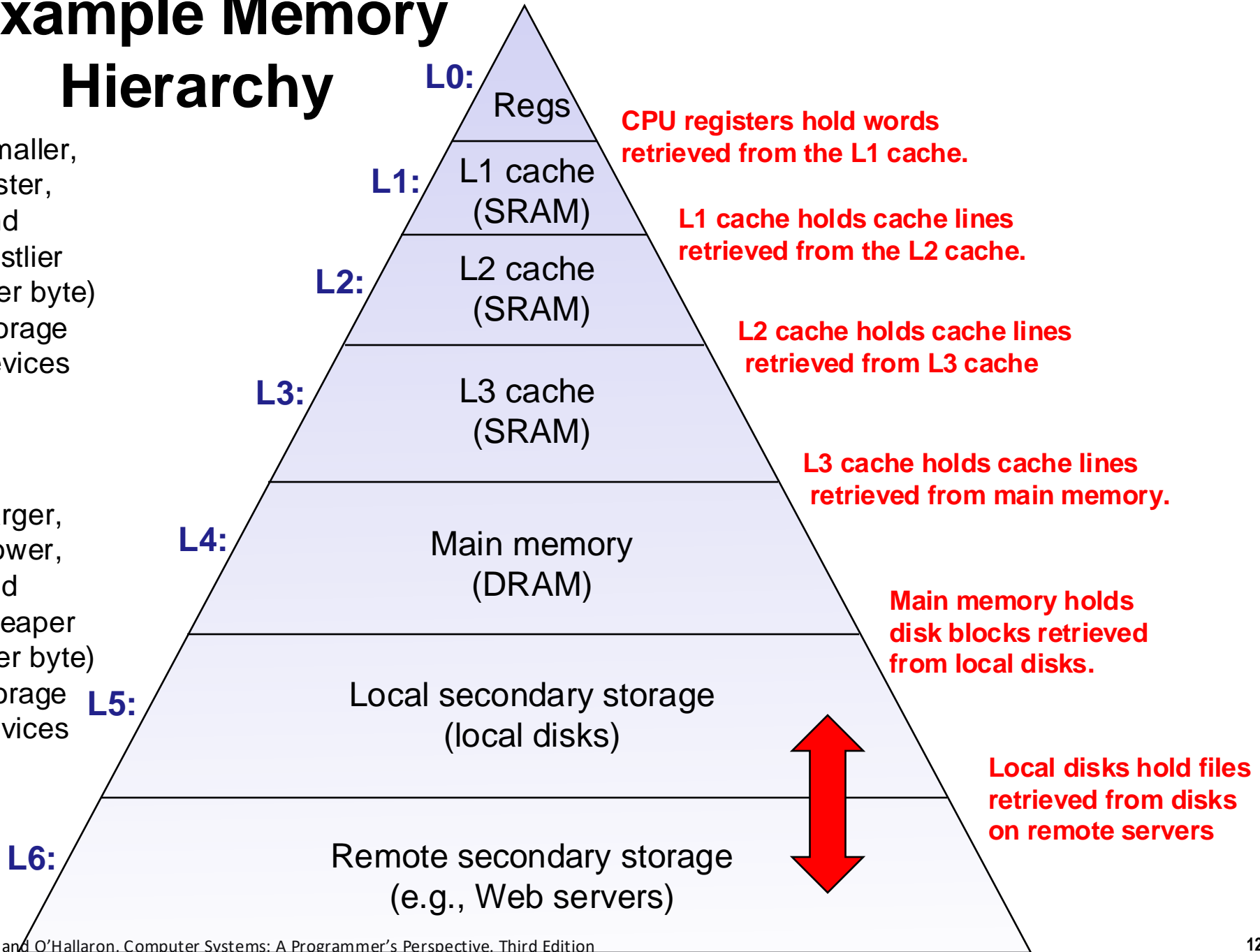

# Computer Networks

- A ***network*** is a hierarchical system of boxes and wires organized by geographical proximity
  - SAN (System Area Network) spans cluster or machine room
    - Switched Ethernet, Quadrics QSW, ...
  - LAN (Local Area Network) spans a building or campus
    - Ethernet is most prominent example
  - WAN (Wide Area Network) spans country or world
    - Typically high-speed point-to-point phone lines
- An ***internetwork (internet)*** is an interconnected set of networks
  - The Global IP Internet (uppercase “I”) is the most famous example of an internet (lowercase “i”)
- **Let’s see how an internet is built from the ground up**

# Lowest Level: Ethernet Segment

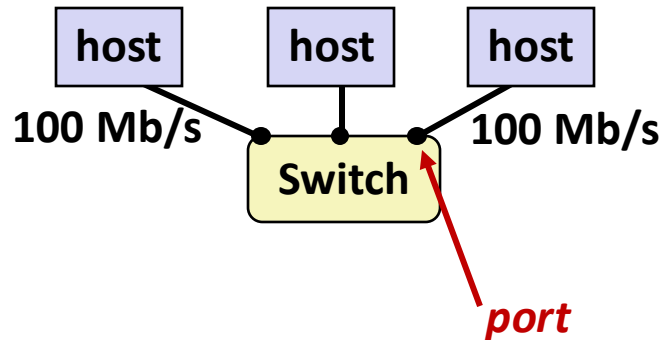

- Ethernet segment consists of a collection of *hosts* connected by wires (twisted pairs) to a *switch*
- Spans room or floor in a building
- Operation
  - Each Ethernet adapter has a unique 48-bit address (MAC address)
    - E.g., 00:16:ea:e3:54:e6
  - Hosts send bits to any other host in chunks called *frames*
  - Bridges (switches, routers) became cheap enough to replace hubs

# Next Level: Bridged Ethernet Segment

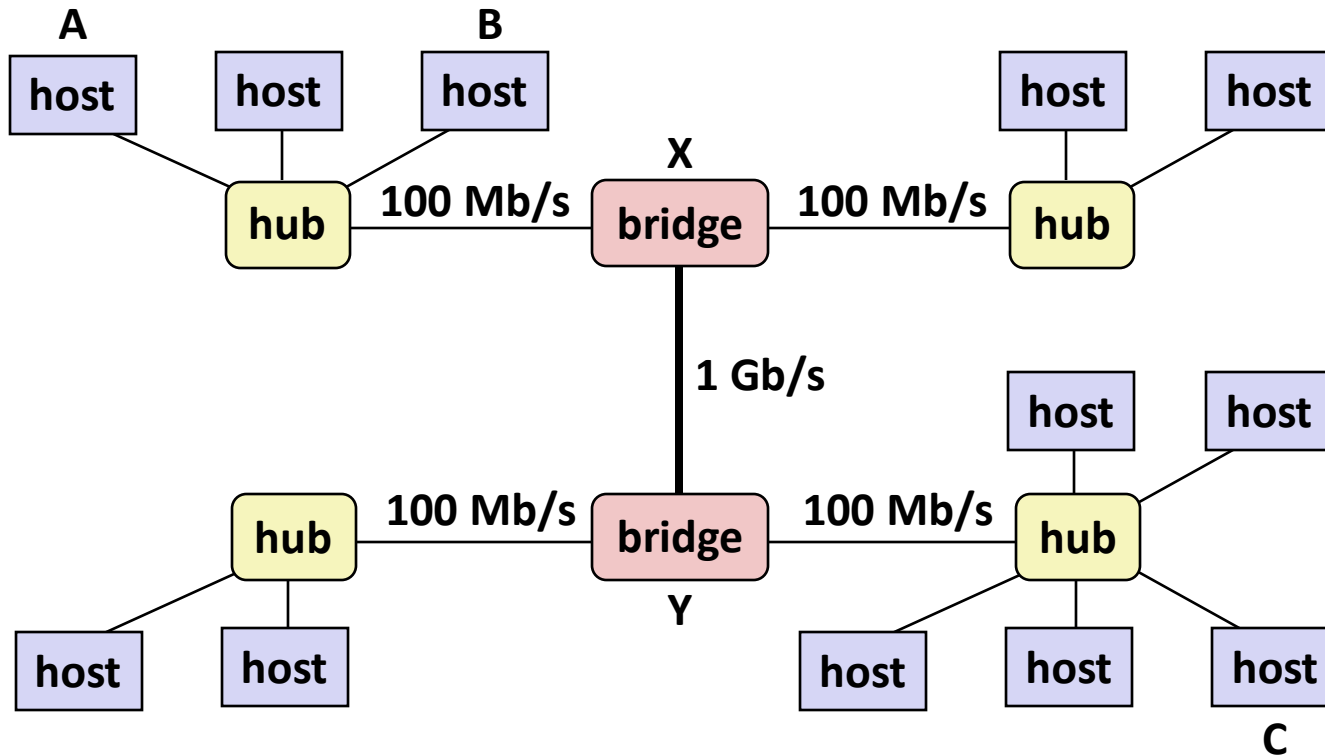

- Spans building or campus
- Bridges cleverly learn which hosts are reachable from which ports and then selectively copy frames from port to port

# Conceptual View of LANs

- For simplicity, hubs, bridges, and wires are often shown as a collection of hosts attached to a single wire:

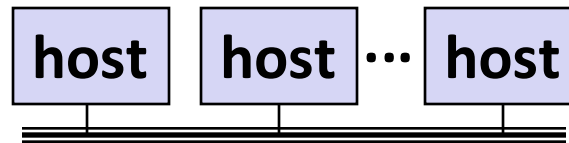



# Next Level: internets

- Multiple incompatible LANs can be physically connected by specialized computers called *routers*
- The connected networks are called an *internet* (lower case)

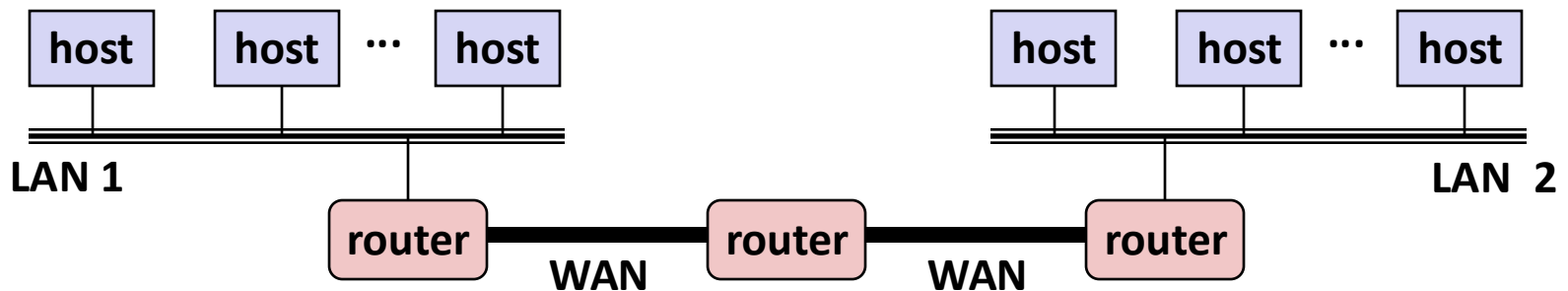

*LAN 1 and LAN 2 might be completely different, totally incompatible (e.g., Ethernet, Fibre Channel, 802.11\*, T1-links, DSL, ...)*

# Logical Structure of an internet

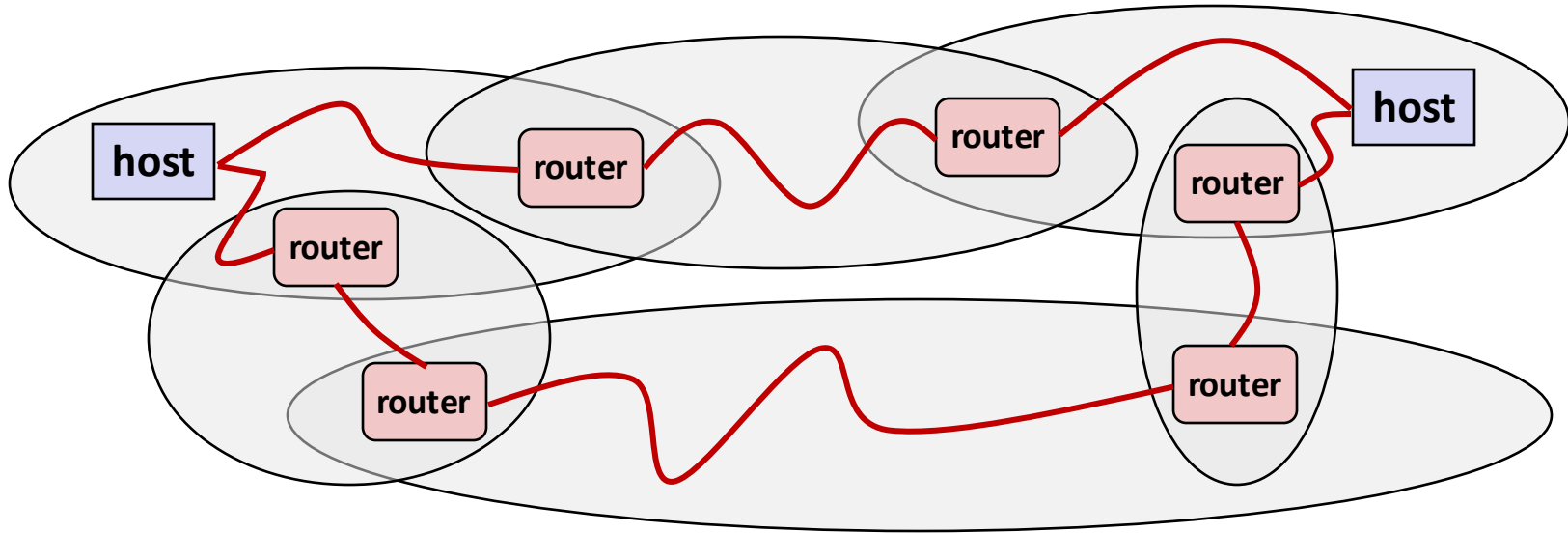

- **Ad hoc interconnection of networks**
  - No particular topology
  - Vastly different router & link capacities
- **Send packets from source to destination by hopping through networks**
  - Router forms bridge from one network to another
  - Different packets may take different routes

# The Notion of an internet Protocol

- How is it possible to send bits across incompatible LANs and WANs?
- Solution: *protocol* software running on each host and router
  - Protocol is a set of rules that governs how hosts and routers should cooperate when they transfer data from network to network.
  - Smooths out the differences between the different networks

# What Does an internet Protocol Do?

## ■ Provides a *naming scheme*

- An internet protocol defines a uniform format for *host addresses*
- Each host (and router) is assigned at least one of these internet addresses that uniquely identifies it

## ■ Provides a *delivery mechanism*

- An internet protocol defines a standard transfer unit (*packet*)
- Packet consists of *header* and *payload*
  - Header: contains info such as packet size, source and destination addresses
  - Payload: contains data bits sent from source host

# Transferring internet Data Via Encapsulation

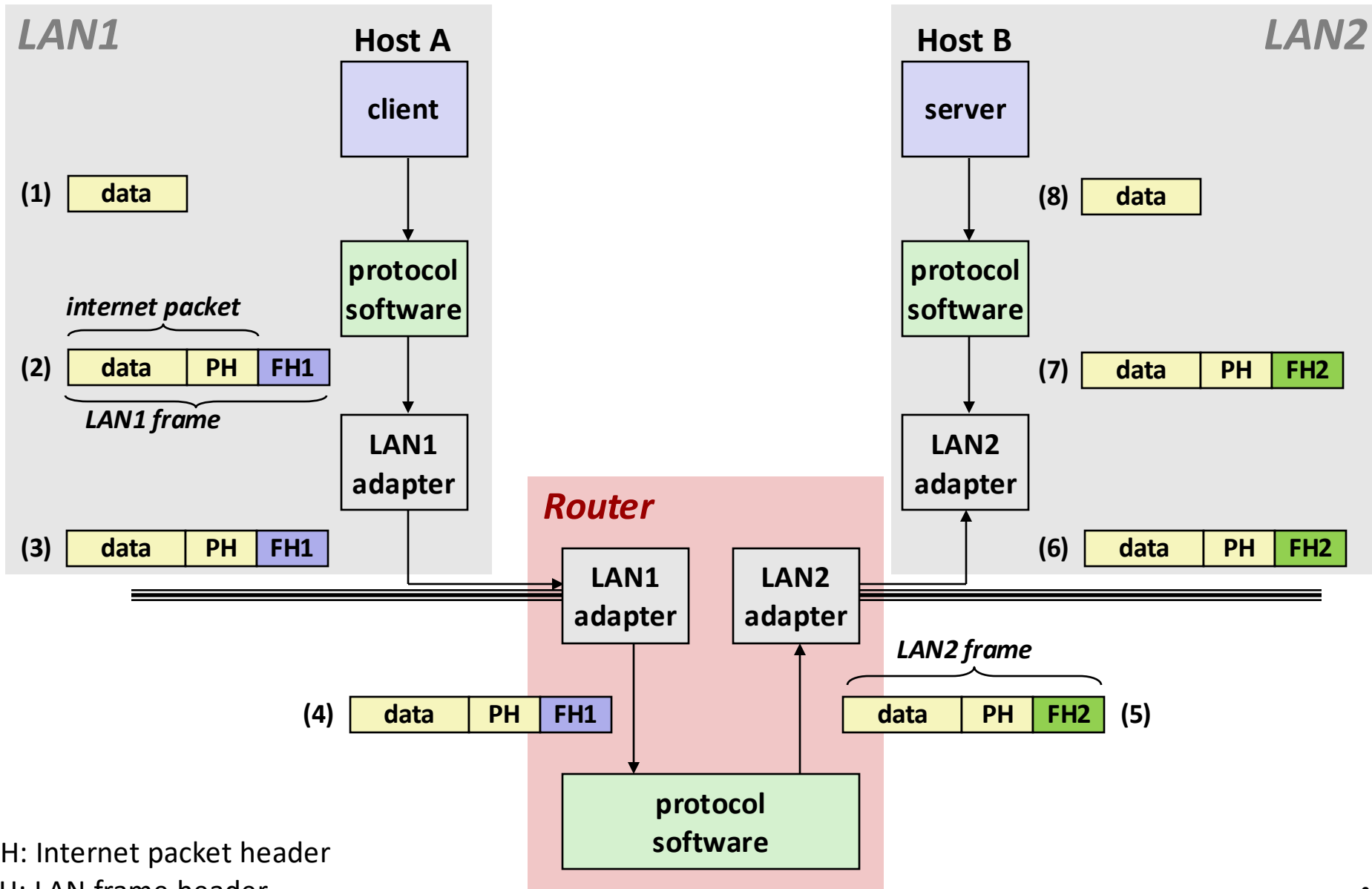

# Other Issues

- **We are glossing over a number of important questions:**
  - What if different networks have different maximum frame sizes? (segmentation)
  - How do routers know where to forward frames?
  - How are routers informed when the network topology changes?
  - What if packets get lost?
- **These (and other) questions are addressed by the area of systems known as *computer networking***

# Global IP Internet (upper case)

- Most famous example of an internet
- Based on the TCP/IP protocol family
  - IP (Internet Protocol) :
    - Provides *basic naming scheme* and unreliable *delivery capability* of packets (datagrams) from *host-to-host*
  - UDP (Unreliable Datagram Protocol)
    - Uses IP to provide *unreliable* datagram delivery from *process-to-process*
  - TCP (Transmission Control Protocol)
    - Uses IP to provide *reliable* byte streams from *process-to-process* over *connections*
- Accessed via a mix of Unix file I/O and functions from the *sockets interface*

# Hardware and Software Organization of an Internet Application

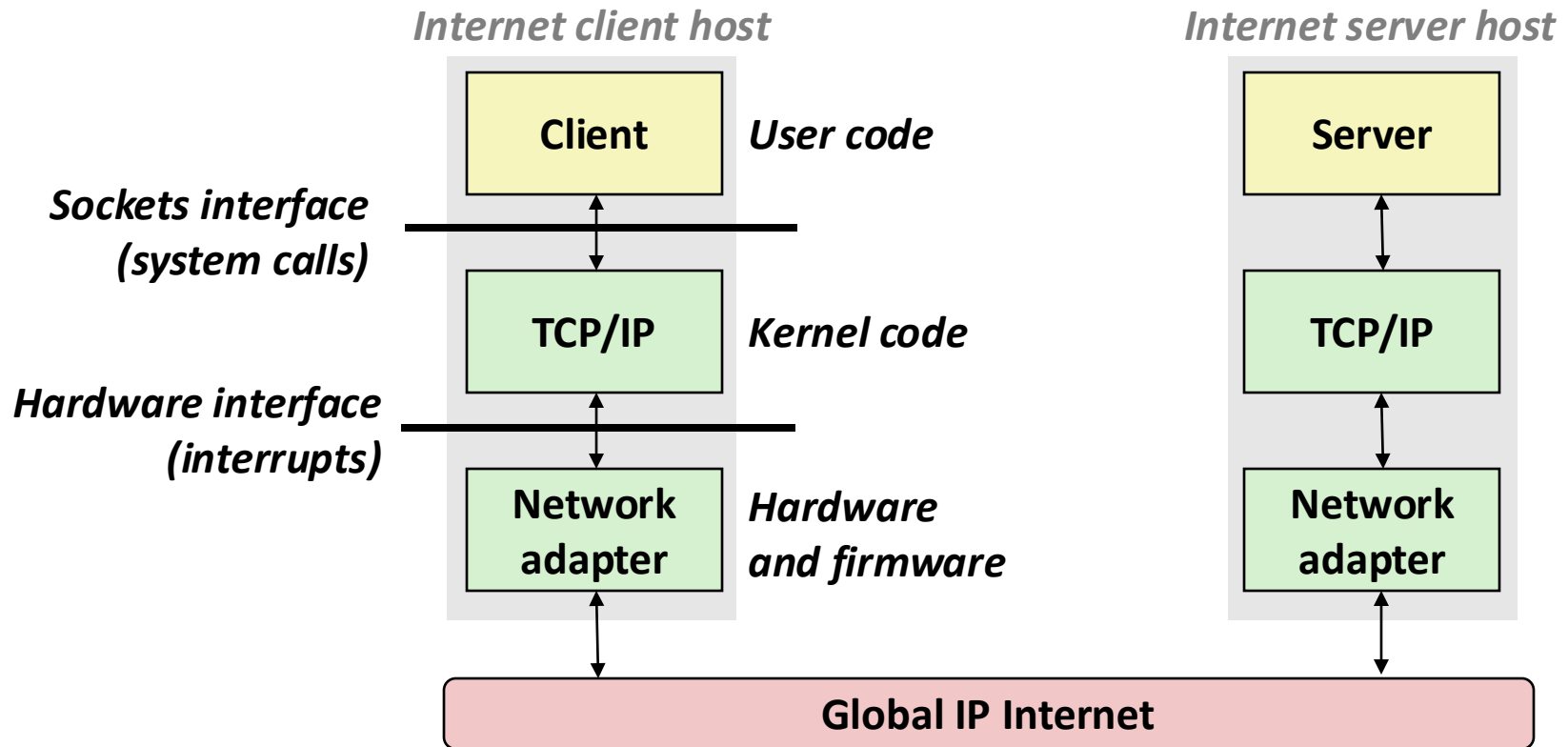



# A Programmer's View of the Internet

1. Hosts are mapped to a set of 32-bit *IP addresses*

- 128.2.203.179

2. The set of IP addresses is mapped to a set of identifiers called Internet *domain names*

- 128.2.203.179 is mapped to `www.cs.cmu.edu`

3. A process on one Internet host can communicate with a process on another Internet host over a *connection*

# Aside: IPv4 and IPv6

- The original Internet Protocol, with its 32-bit addresses, is known as *Internet Protocol Version 4 (IPv4)*
- 1996: Internet Engineering Task Force (IETF) introduced *Internet Protocol Version 6 (IPv6)* with 128-bit addresses
  - Intended as the successor to IPv4
- As of 2024, the majority of Internet traffic is still carried by IPv4
  - About 45% of users access Google services using IPv6.
  - 31% in Australia.
- We will focus on IPv4, but will show you how to write networking code that is protocol-independent.

# IPv6 Adoption

## IPv6 Adoption

We are continuously measuring the availability of IPv6 connectivity among Google users. The graph shows the percentage of users that access Google over IPv6.

Native: 40.82% 6to4/Teredo: 0.00% Total IPv6: 40.82% | Jul 5, 2023

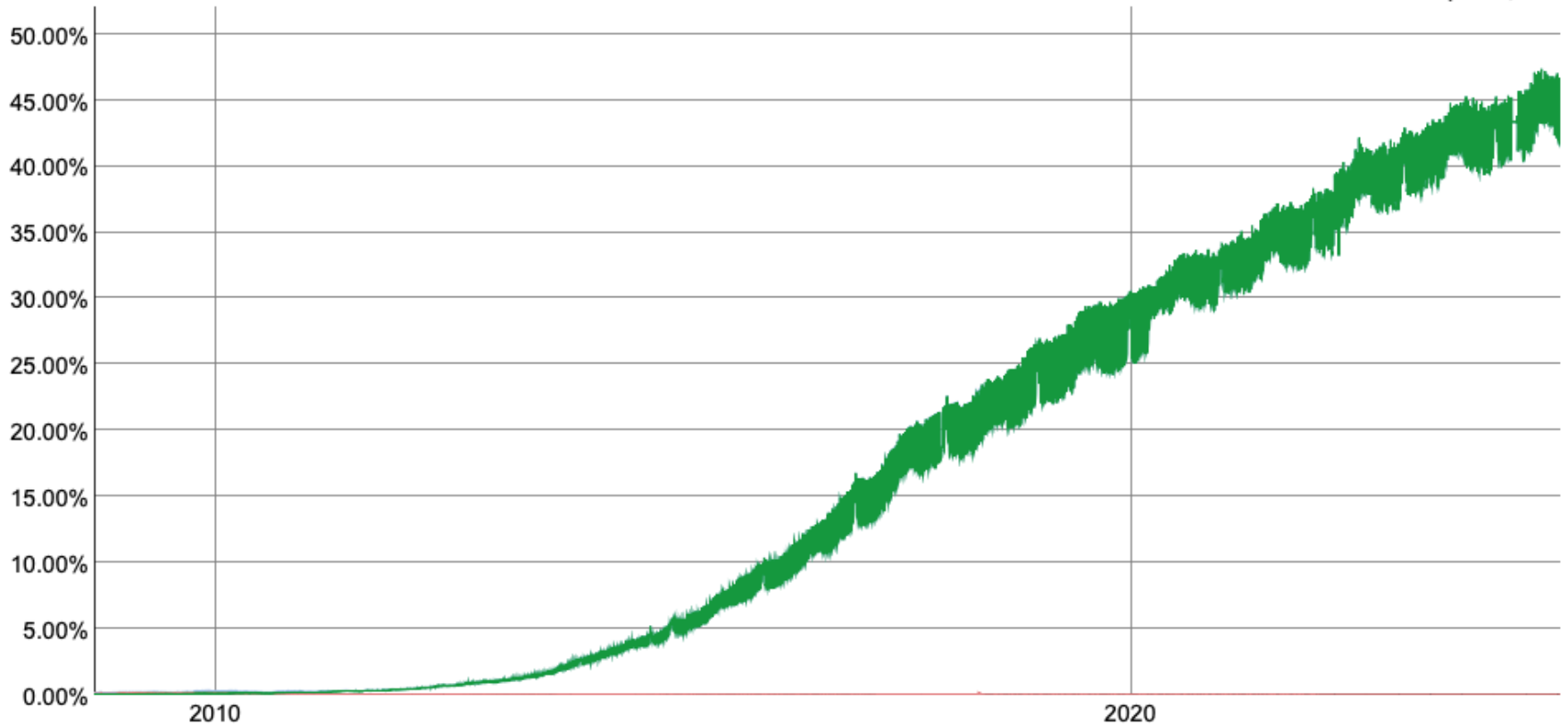

Source: Google (14 Sep. 24)

# (1) IP Addresses

- **32-bit IP addresses are stored in an *IP address struct***
  - IP addresses are always stored in memory in *network byte order* (big-endian byte order)
  - True in general for any integer transferred in a packet header from one machine to another.
    - E.g., the port number used to identify an Internet connection.

```
/* Internet address structure */  
struct in_addr {  
    uint32_t  s_addr; /* network byte order (big-endian) */  
};
```

# Dotted Decimal Notation

- By convention, each byte in a 32-bit IP address is represented by its decimal value and separated by a period
  - IP address: `0x8002C2F2` = `128.2.194.242`
- Use `getaddrinfo` and `getnameinfo` functions (described later) to convert between IP addresses and dotted decimal format.

## (2) Internet Domain Names

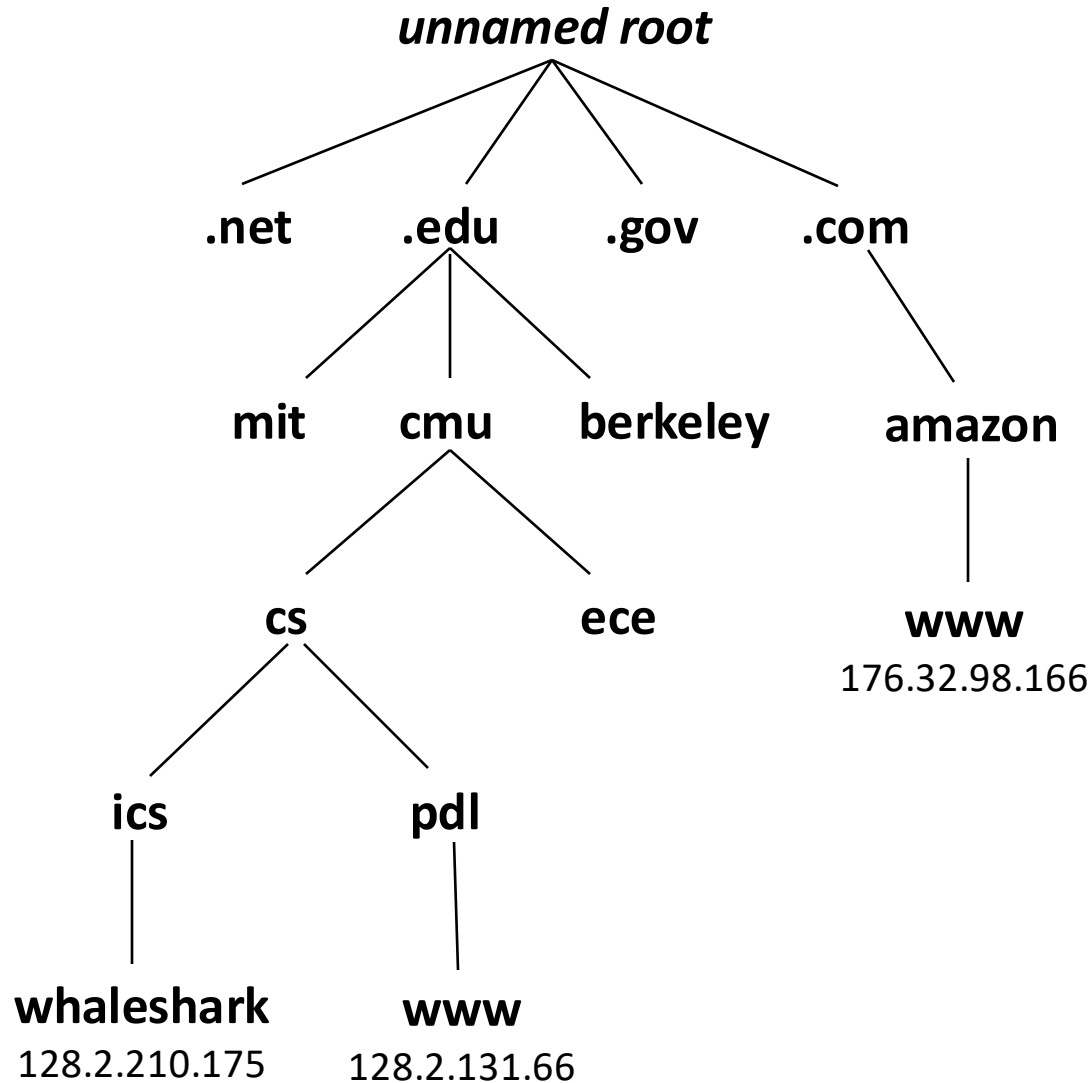

*First-level domain names*

*Second-level domain names*

*Third-level domain names*

# Domain Naming System (DNS)

- The Internet maintains a mapping between IP addresses and domain names in a huge worldwide distributed database called *DNS*
- Conceptually, programmers can view the DNS database as a collection of billions of *host entries*.
  - Each host entry defines the mapping between a set of domain names and IP addresses.
  - In a mathematical sense, a host entry is an equivalence class of domain names and IP addresses.

# Properties of DNS Mappings

- Can explore properties of DNS mappings using `nslookup`

- Output edited for brevity

- Each host has a locally defined domain name `localhost` which always maps to the *loopback address* `127.0.0.1`

```
linux> nslookup localhost
Address: 127.0.0.1
```

- Use `hostname` to determine real domain name of local host:

```
linux> hostname
whaleshark.ics.cs.cmu.edu
```



# Properties of DNS Mappings (cont)

- **Simple case: one-to-one mapping between domain name and IP address:**

```
linux> nslookup whaleshark.ics.cs.cmu.edu  
Address: 128.2.210.175
```

- **Multiple domain names mapped to the same IP address:**

```
linux> nslookup cs.mit.edu  
Address: 18.62.1.6  
linux> nslookup eecs.mit.edu  
Address: 18.62.1.6
```

# Properties of DNS Mappings (cont)

- Multiple domain names mapped to multiple IP addresses:

```
linux> nslookup www.x.com
Address: 104.244.42.193
Address: 104.244.42.1
Address: 104.244.42.129
Address: 104.244.42.65
```

```
linux> nslookup www.x.com
Address: 104.244.42.1
Address: 104.244.42.65
Address: 104.244.42.129
Address: 104.244.42.193
```

- Some valid domain names don't map to any IP address:

```
linux> nslookup ics.cs.cmu.edu
*** Can't find ics.cs.cmu.edu: No answer
```

# (3) Internet Connections

- Clients and servers communicate by sending streams of bytes over **connections**. Each connection is:
  - *Point-to-point*: connects a pair of processes.
  - *Full-duplex*: data can flow in both directions at the same time,
  - *Reliable*: stream of bytes sent by the source is eventually received by the destination in the same order it was sent.
- A **socket** is an endpoint of a connection
  - *Socket address* is an `IPAddress:port` pair
- A **port** is a 16-bit integer that identifies a process:
  - **Ephemeral port**: Assigned automatically by client kernel when client makes a connection request.
  - **Well-known port**: Associated with some **service** provided by a server (e.g., port 80 is associated with Web servers)

# Well-known Ports and Service Names

- Popular services have permanently assigned *well-known ports* and corresponding *well-known service names*:
  - echo server: 7/echo
  - ssh servers: 22/ssh
  - email server: 25/smtp
  - Web servers: 80/http
- Mappings between well-known ports and service names is contained in the file `/etc/services` on each Linux machine.

# Anatomy of a Connection

- A connection is uniquely identified by the socket addresses of its endpoints (*socket pair*)
  - (cliaddr:cliport, servaddr:servport)

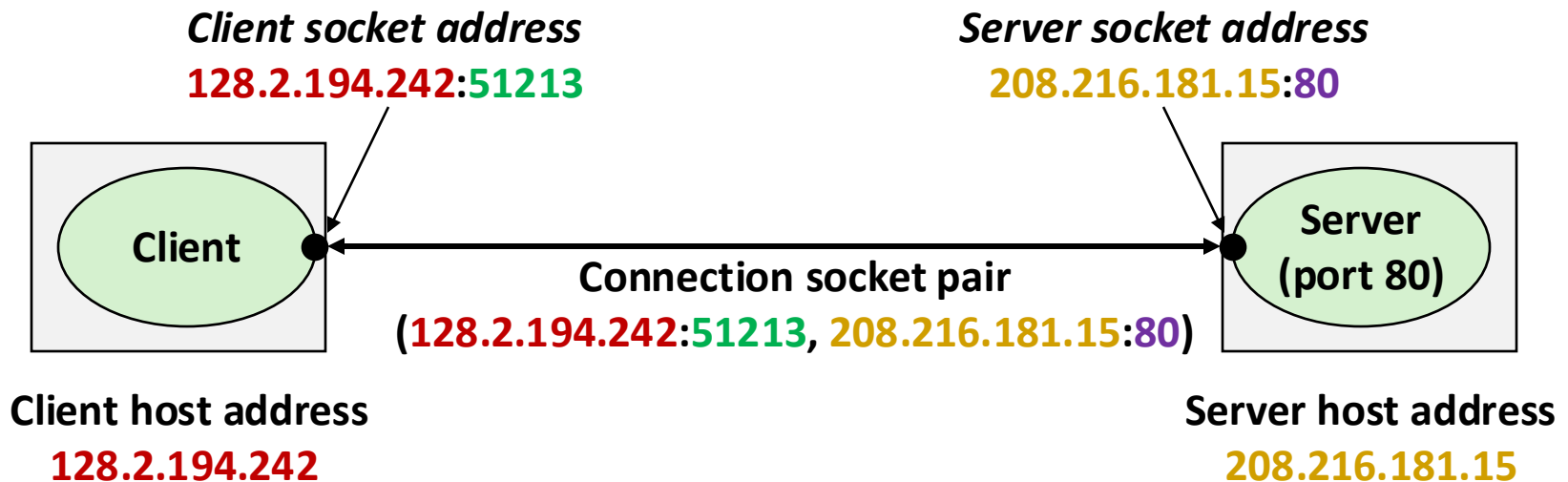

**51213** is an ephemeral port allocated by the kernel

**80** is a well-known port associated with Web servers

# Using Ports to Identify Services

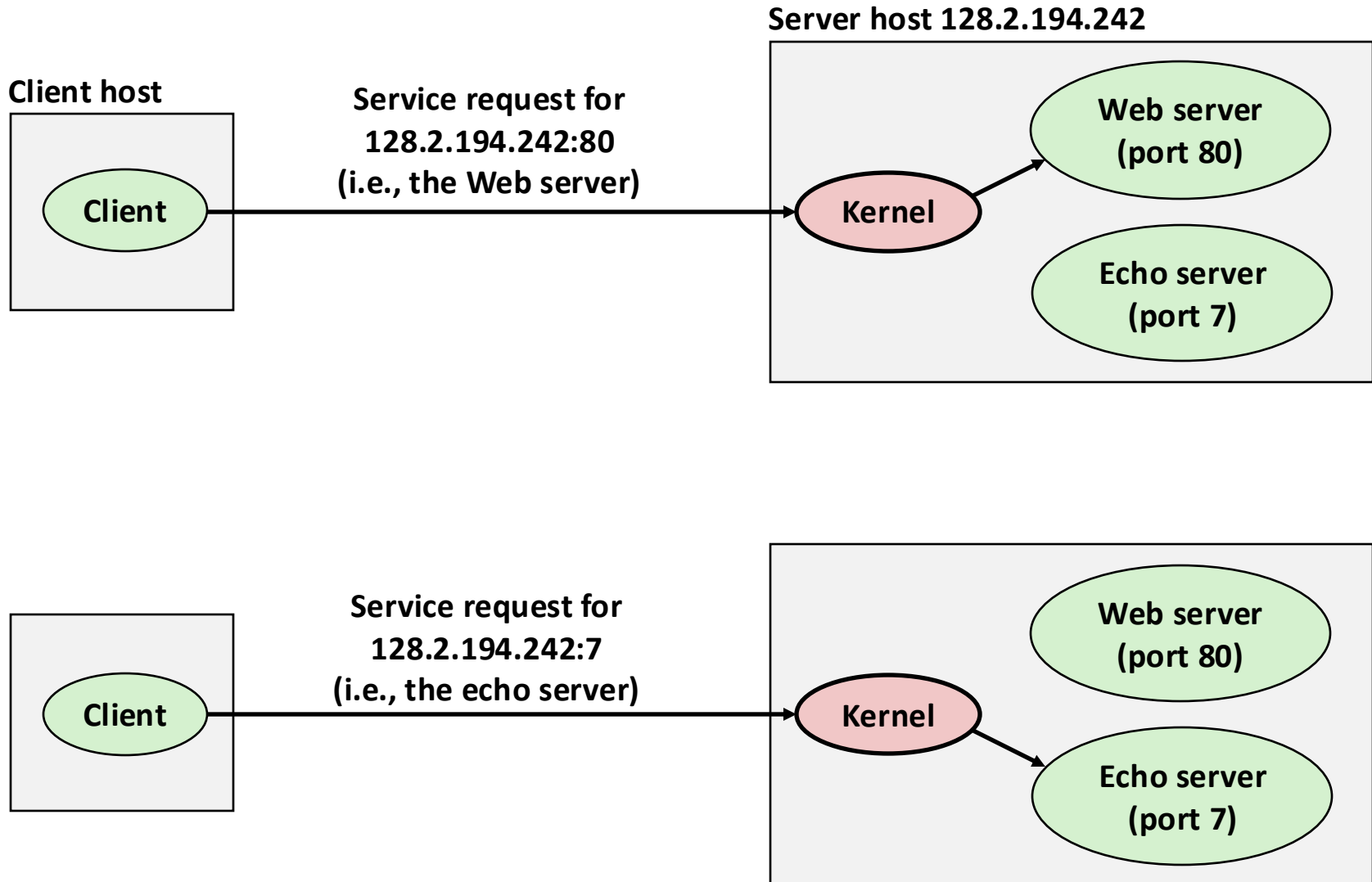

# Sockets Interface

- **Set of system-level functions used in conjunction with Unix I/O to build network applications.**
- **Created in the early 80's as part of the original Berkeley distribution of Unix that contained an early version of the Internet protocols.**
- **Available on all modern systems**
  - Unix variants, Windows, OS X, IOS, Android, ARM

# Sockets

## ■ What is a socket?

- To the kernel, a socket is an endpoint of communication
- To an application, a socket is a file descriptor that lets the application read/write from/to the network
  - **Remember:** All Unix I/O devices, including networks, are modeled as files

## ■ Clients and servers communicate with each other by reading from and writing to socket descriptors

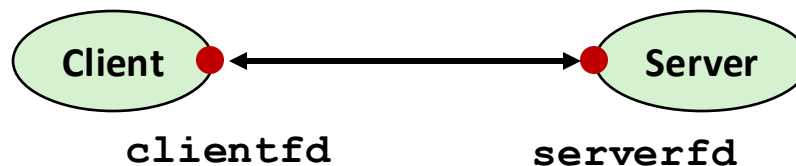

## ■ The main distinction between regular file I/O and socket I/O is how the application “opens” the socket descriptors



# Socket Address Structures

## ■ Generic socket address:

- For address arguments to **connect**, **bind**, and **accept**
- Necessary only because C did not have generic (**void \***) pointers when the sockets interface was designed
- For casting convenience, we adopt the Stevens convention:

```
typedef struct sockaddr SA;
```

```
struct sockaddr {  
    uint16_t  sa_family;    /* Protocol family */  
    char      sa_data[14]; /* Address data. */  
};
```

sa\_family

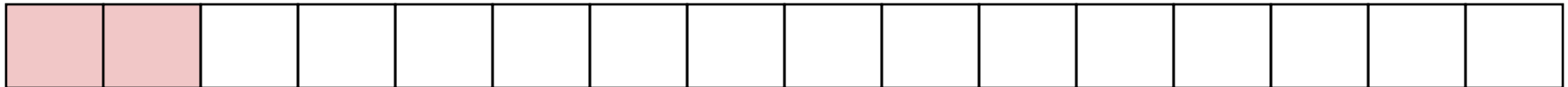

Family Specific

# Socket Address Structures

## ■ Internet-specific socket address:

- Must cast `(struct sockaddr_in *)` to `(struct sockaddr *)` for functions that take socket address arguments.

```
struct sockaddr_in {
    uint16_t      sin_family; /* Protocol family (always AF_INET) */
    uint16_t      sin_port;   /* Port num in network byte order */
    struct in_addr sin_addr;  /* IP addr in network byte order */
    unsigned char sin_zero[8]; /* Pad to sizeof(struct sockaddr) */
};
```

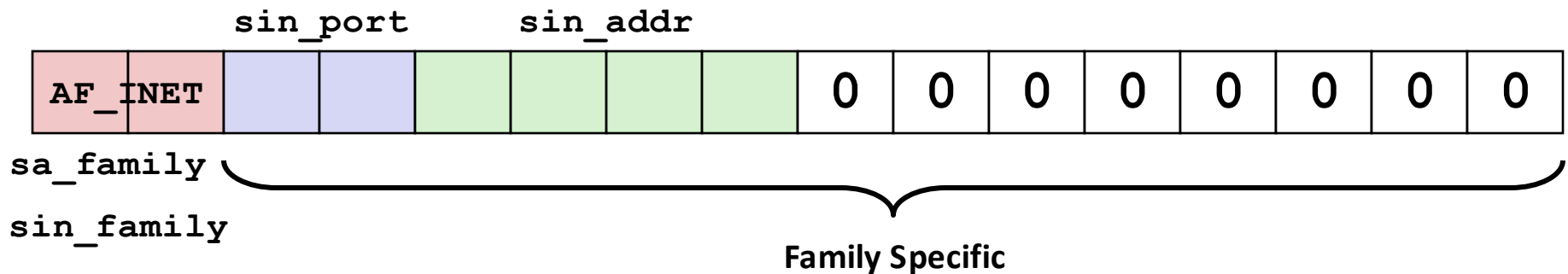

# Sockets Interface

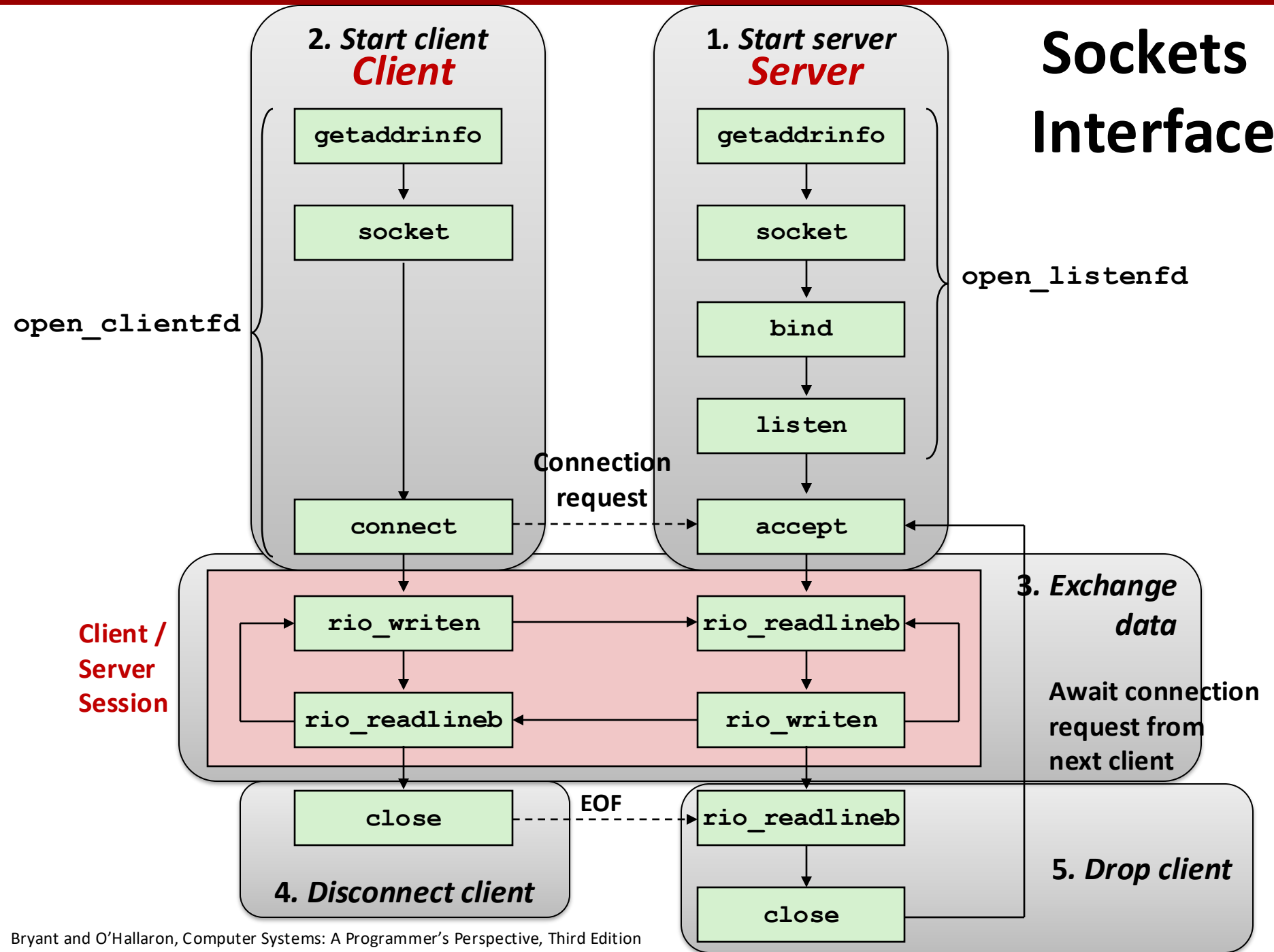

# Sockets Interface

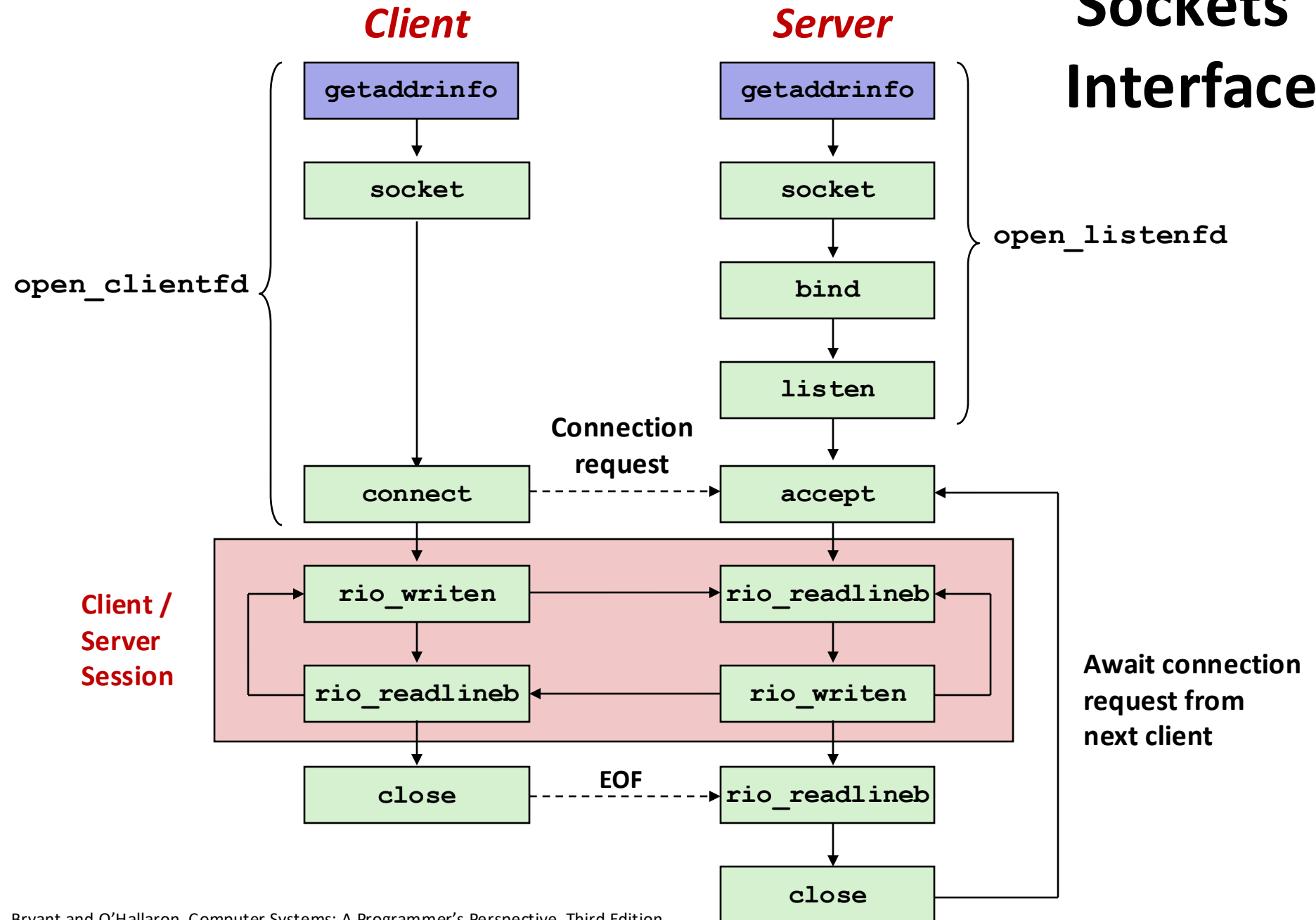

# Host and Service Conversion: `getaddrinfo`

- `getaddrinfo` is the modern way to convert string representations of hostnames, host addresses, ports, and service names to socket address structures.
  - Replaces obsolete `gethostbyname` and `getservbyname` funcs.
- **Advantages:**
  - Reentrant (can be safely used by threaded programs).
  - Allows us to write portable protocol-independent code
    - Works with both IPv4 and IPv6
- **Disadvantages**
  - Somewhat complex
  - Fortunately, a small number of usage patterns suffice in most cases.

# Host and Service Conversion: `getaddrinfo`

```
int getaddrinfo(const char *host,          /* Hostname or address */
               const char *service,      /* Port or service name
*/
               const struct addrinfo *hints, /* Input parameters */
               struct addrinfo **result); /* Output linked list */

void freeaddrinfo(struct addrinfo *result); /* Free linked list */

const char *gai_strerror(int errcode);    /* Return error msg */
```

- Given `host` and `service`, `getaddrinfo` returns `result` that points to a linked list of `addrinfo` structs, each of which points to a corresponding socket address struct, and which contains arguments for the sockets interface functions.
- **Helper functions:**
  - `freeaddrinfo` frees the entire linked list.
  - `gai_strerror` converts error code to an error message.

# Linked List Returned by `getaddrinfo`

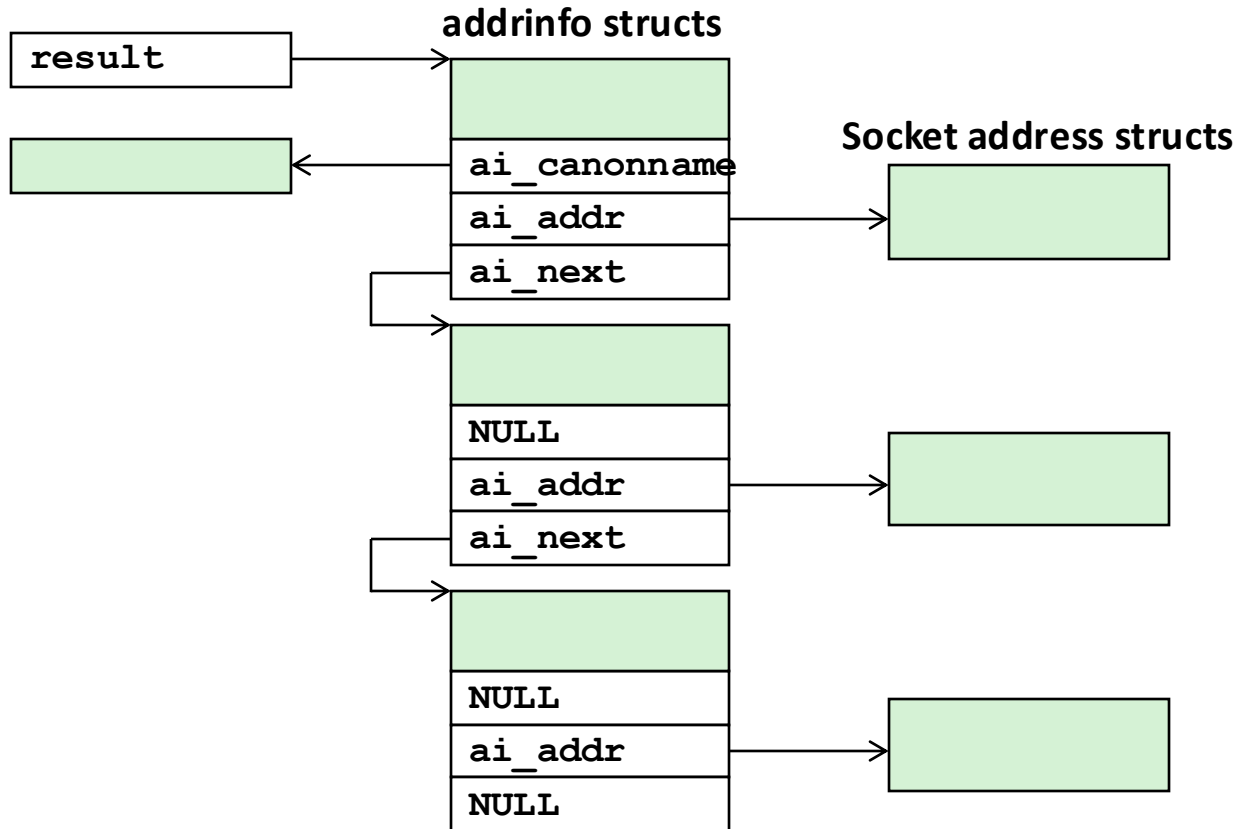

- **Clients:** walk this list, trying each socket address in turn, until the calls to `socket` and `connect` succeed.
- **Servers:** walk the list until calls to `socket` and `bind` succeed.

# addrinfo Struct

```
struct addrinfo {
    int          ai_flags;      /* Hints argument flags */
    int          ai_family;    /* First arg to socket function */
    int          ai_socktype;  /* Second arg to socket function */
    int          ai_protocol;  /* Third arg to socket function */
    char        *ai_canonname; /* Canonical host name */
    size_t       ai_addrlen;   /* Size of ai_addr struct */
    struct sockaddr *ai_addr;  /* Ptr to socket address structure */
    struct addrinfo *ai_next;  /* Ptr to next item in linked list */
};
```

- Each `addrinfo` struct returned by `getaddrinfo` contains arguments that can be passed directly to `socket` function.
- Also points to a socket address struct that can be passed directly to `connect` and `bind` functions.



# Host and Service Conversion: `getnameinfo`

- `getnameinfo` is the inverse of `getaddrinfo`, converting a socket address to the corresponding host and service.
  - Replaces obsolete `gethostbyaddr` and `getservbyport` funcs.
  - Reentrant and protocol independent.

```
int getnameinfo(const SA *sa, socklen_t salen, /* In: socket addr */
               char *host, size_t hostlen, /* Out: host */
               char *serv, size_t servlen, /* Out: service */
               int flags); /* optional flags */
```

# Conversion Example

```
#include "csapp.h"

int main(int argc, char **argv)
{
    struct addrinfo *p, *listp, hints;
    char buf[MAXLINE];
    int rc, flags;

    /* Get a list of addrinfo records */
    memset(&hints, 0, sizeof(struct addrinfo));
    hints.ai_family = AF_INET;          /* IPv4 only */
    hints.ai_socktype = SOCK_STREAM; /* Connections only */
    if ((rc = getaddrinfo(argv[1], NULL, &hints, &listp)) != 0) {
        fprintf(stderr, "getaddrinfo error: %s\n", gai_strerror(rc));
        exit(1);
    }
}
```

hostinfo.c

# Conversion Example (cont)

```
/* Walk the list and display each IP address */
flags = NI_NUMERICHOST; /* Display address instead of name */
for (p = listp; p; p = p->ai_next) {
    Getnameinfo(p->ai_addr, p->ai_addrlen,
                buf, MAXLINE, NULL, 0, flags);
    printf("%s\n", buf);
}

/* Clean up */
Freeaddrinfo(listp);

exit(0);
}
```

hostinfo.c

# Running hostinfo

```
whaleshark> ./hostinfo localhost
```

```
127.0.0.1
```

```
whaleshark> ./hostinfo whaleshark.ics.cs.cmu.edu
```

```
128.2.210.175
```

```
whaleshark> ./hostinfo twitter.com
```

```
199.16.156.230
```

```
199.16.156.38
```

```
199.16.156.102
```

```
199.16.156.198
```

# Next time

- Using `getaddrinfo` for host and service conversion
- Writing clients and servers
- Writing Web servers!